



SAS & FC COMPARED

THE R/EVOLUTION DIFFERENCE

white paper

SAS vs. FC



SAS & FC COMPARED

THE R/EVOLUTION DIFFERENCE

TABLE OF CONTENTS

Introduction	3
SAS (Serial Attached SCSI) - the New SCSI	3
Market Timing	3
SAS and FC Similarities	4
SAS Benefits	5
Combining the Best of Both Worlds	5
End-to-End FC Interface Removed	6
Utmost Flexibility	6
Seamless Scalability & Improved Cost of Ownership	6
The Nature of SAS and FC Drives	6
Will SAS Upstage Fibre Channel?	7
SAS Roadmap	7
Conclusion	8

white paper

SAS vs. FC

SAS & Fibre Channel - Compared

Introduction

In today's economy, cost-effective, performance-oriented, scalable and reliable storage solutions are fundamental to success. Today's IT managers as well as storage vendors need to keep their competitive edge by continuing to reduce the cost of their operations and solutions. No matter what the company size, the process of scrutinizing access time to data is occurring. As the value to the access of data increases the utilization of storage resources, it also exposes the issue that not all data is the same. Often, this is a function of the age of data. IT managers are looking for more cost-effective, high-performance storage, as well as to maximize the efficiency of their IT spending.

This paper explores SAS – a relatively new entry into the disk drive market – as a very viable replacement for Fibre Channel-based (FC) disk drives. Although it is not a complete replacement for FC, SAS will eventually come to command the midrange disk market for external storage.

SAS (Serial Attached SCSI) - the New SCSI

Foreseeing the end of the traditional SCSI drive interface, a group of storage industry leaders, including representatives from system, controller, and hard drive companies, met to define a new interface that would become known as Serial Attached SCSI, or SAS. The conversion of Parallel SCSI to SAS started in 2002. In 2003, the ANSI standard was passed allowing the industry to initiate a new beginning. Starting roughly, where the Parallel SCSI ended, at 320Mbps performance, SAS is an improvement by being a point-to-point, full duplex, dual-port interface. Although cable lengths are

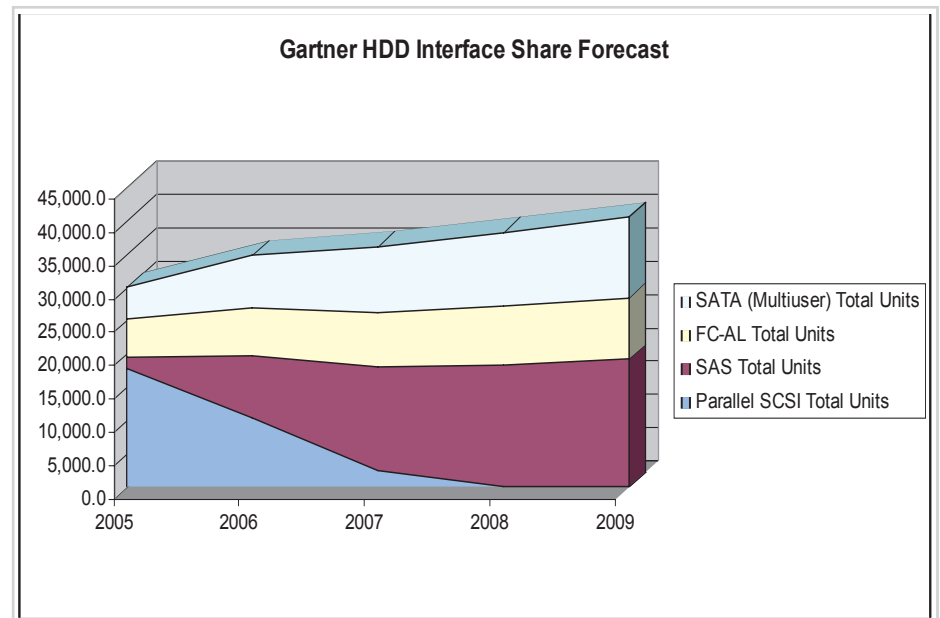

Figure 1. Source Gartner 2005

restricted to 10 meters with no optical capability, SAS permits simultaneous input and output transfers to be full duplex active at each communicating port.

SAS will ultimately replace traditional Parallel SCSI drives, which have been around for the better part of two decades and have reached their performance limit. Parallel interfaces have become technologically more challenging as their respective clock frequencies have increased to keep pace with the bandwidth requirements of their attached storage devices. Introduced in 1986, the SCSI interface offered an 8-bit data bus. Improvements expanded it to a 16-bit data bus, leaping the performance from 10Mb per second to 20Mb per second without increasing the clock speed. In 2001, the maximum clock speed for SCSI attained 320 MHz (maximum burst rate of 320MB per second) after overcoming significant obstacles such as signal distortion ("cross-talk") and skewing errors. In addition, unwieldy cables, the

prevention of skewing errors and signal distortion further contributed to the demise of the parallel interface - further development ceased. To gain more head room for performance and longevity, SAS is now SCSI's future

Market Timing

Because of its trusted reliability and stable feature set, the SCSI protocol has been accepted by the market for a remarkable 20 years. The SCSI interface has long been the backbone of performance-based systems but has all but run out of steam due to its parallel architecture. Introduced three years ago, Serial Attached SCSI (SAS) leverages this continuing evolution of SCSI with new levels of scalability, flexibility, and cost-effectiveness for connectivity, data transport, and data storage.

The first SAS prototypes were announced in 2003 and were a major step to achieving mass market availability. Those prototypes allowed development of the first

SAS & Fibre Channel - Compared

generation of technologies and products that will bring the benefits of SAS into the enterprise. These products have now been developed and tested, and a wide variety of integrated solutions have been demonstrated.

Interoperability testing was a key component of SAS, because it increases the architecture's flexibility by supporting both SAS and Serial ATA (SATA) disk drives and components. Conducted throughout 2004, the University of New Hampshire InterOperability Laboratory successfully demonstrated all the required levels of interoperability in a variety of SAS products and configurations. Interoperability allows one vendor's SAS products to be compatible with another's, and it also ensures products developed today will work with all existing and next-generation SATA products.

The same companies that pioneered SCSI are investing in the evolution of SAS to maintain its high reliability standards while meeting the market's evolving technology and functionality requirements. Industry support comes from all of the major disk drive vendors, host adapter suppliers, chipset manufacturers, large computer makers, and many other suppliers.

In 2005, SAS disk drives shipped in very modest quantities, yet are anticipated to capture a majority of the market within the next two years (note Figure 1). Experts are predicting SAS drives will be the hottest storage media to come along since Serial ATA (SATA), its lower-end counterpart, while offering a lower-cost alternative to Fibre Channel drives, its higher-end counterpart. SAS is likely to become a standard by the end of 2006, much like SATA replaced ATA drives on all but the lowest-end PCs.

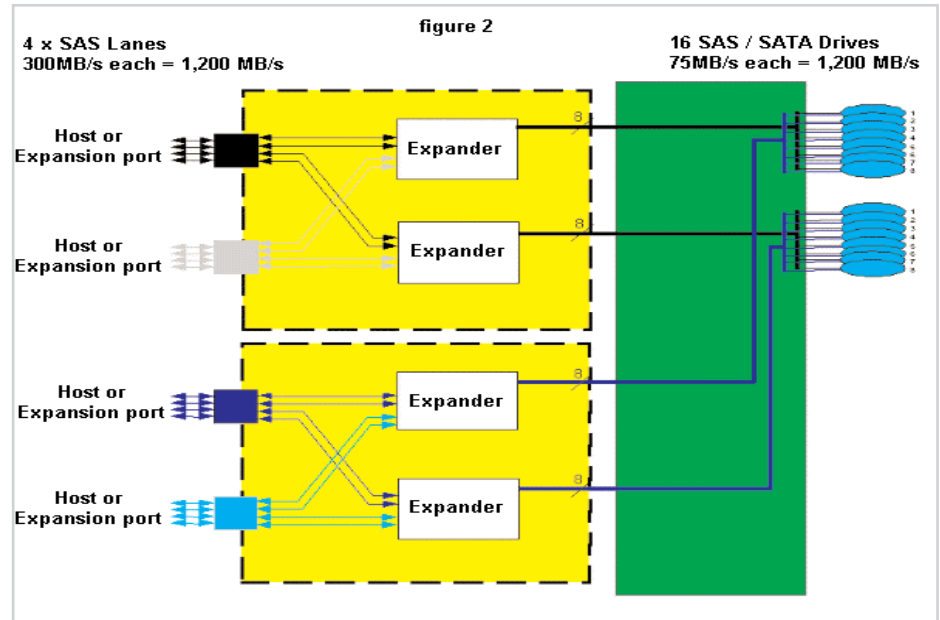

Figure 2. R/Evolution SAS Architecture

SAS and FC Similarities

Both FC and SAS offer the maturity, richness, depth and scope of the SCSI command set. They are differentiated by their drive-to-drive connectivity, their inter-box connectivity and their addressability. FC's combination of shared media access, data rate, optical support and fabric compatibility has made it the interface of choice for SANs and high-speed switching environments.

The newest FC drives available today support 4 Gbps¹ a data transfer rate of up to 400 MBps half-duplex and up to 800 MBps full-duplex, per port. On the heels of 4 Gb FC, SAS has received a great deal of market attention due to several performance benefits. Supporting data transfer rates of up to 3 Gbps and full duplex, point-to-point connections (so that each drive has a dedicated connection to the host or RAID controller), a SAS connection can support four wide lanes or 4 x 300 MB/s per connection. SAS will compete with FC in all but the most highly

data intensive transactional applications.

For example, a SAS connection on a JBOD system can support a theoretical maximum of 1,200 MB/s (see figure 2). SAS is also used as a high performance yet cost-effective expansion port to daisy chain to another SAS subsystem.

SAS drives, like Fibre Channel drives, are designed for the rigors of enterprise use and heavy loads, have MTBF ratings in excess of 1 million hours and warranties up to 5 years. Both SAS and FC drives are engineered for rugged enterprise duty, and every component (drive motor, spindle, actuator, firmware, etc.) is specifically designed and manufactured for that rigorous use. SAS drives also safeguard data integrity via their comprehensive verification/error correction capabilities.

1. The 4Gb FC interface is backward compatible with 2 Gb FC.

SAS & Fibre Channel - Compared

SAS drive-based subsystems also support the following:

- "Active-active controllers for failover
- "Redundant host connections that could be SAS, Fibre Channel or iSCSI
- "Fibre Channel or iSCSI
- "Redundant hot swappable power, cooling, controllers and disks
- "Enclosure services and the same RAID and software capabilities found in Fibre Channel and SCSI-based arrays.

Given the superior price/performance ratio and reliability equivalence to FC drives, unit sales for SAS drives will grow significantly in the next few years. Overall unit shipments for SAS will grow modestly, while FC drives units will remain relatively flat with SATA drives showing continued growth as well.

SAS Benefits

Relative to parallel SCSI, Serial Attached SCSI drives (SAS) will have much more throughput and higher levels of performance. Most notably, SAS drives can send and receive data simultaneously or serially. SAS drives support speeds of up to 15,000 RPM; double that of SATA drives.

From a cost perspective, SAS drives will be priced similarly to Parallel SCSI drives, and be less expensive than Fibre Channel drives and related infrastructure. Fibre Channel will not phase out. However, SAS will become the drive of choice for most performance related applications. In addition, each 3 Gb high performance SAS drive (10K rpm or 15K rpm) is connected to a 3Gb drive connection, providing more than enough bandwidth for the highest performing drives. SAS features a point-to-point architecture, in which all storage devices connect directly to an expanding switching matrix rather than

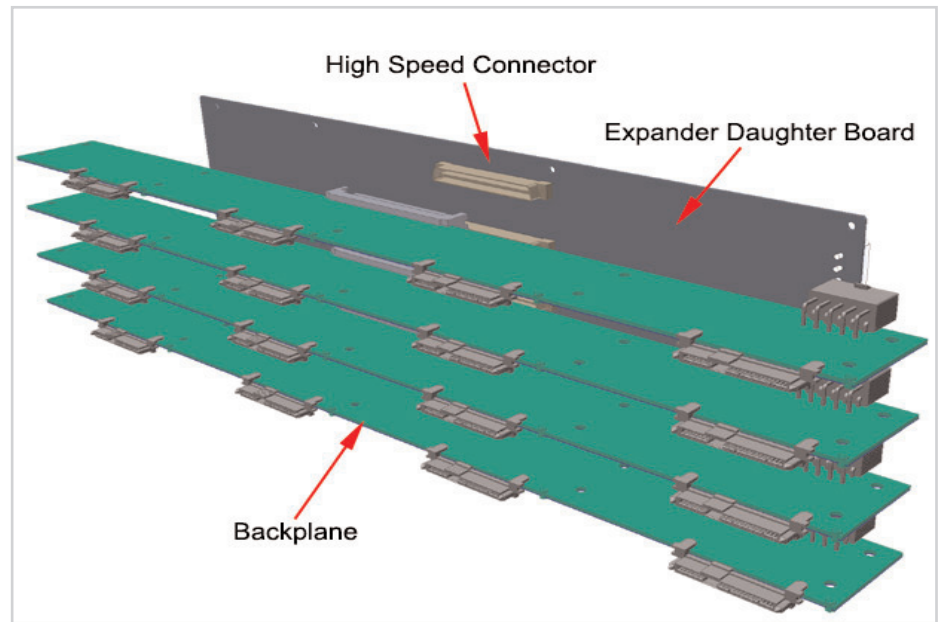

Figure 3 SAS Expander

sharing a common bus as traditional SCSI devices do, essentially increasing data throughput and improving the ability to locate and fix disk failures. SAS inherits its command set from parallel SCSI, its frame formats from Fibre Channel, and its physical characteristics from Serial ATA.

Combining the Best of Both Worlds

Until recently, attaching multiple Fibre Channel hard drives in a RAID system via FC met nearly all performance requirements for many IT environments. Then the concept of tiered storage became more tangible when SATA hard drives were introduced, offering much higher capacity and lower cost though lower per-

formance. SATA drives began to replace SCSI drives as a result. The decision WAS simple: choose FC hard drives for applications that require any type of performance; then choose SATA hard drives when low cost storage and/or high capacity is required. The addition of SAS has increased the options IT managers have to solve their disk storage challenges providing an alternative solution for high performance applications with an attractive price/performance. SAS will garner most of the market for external storage. Fibre Channel disk drives, as Gartner and IDC have forecasted will be found installed in applications where performance requirements exceed the price-to-performance attributes SAS offers. SATA will continue to be the storage choice for economic driven applications.

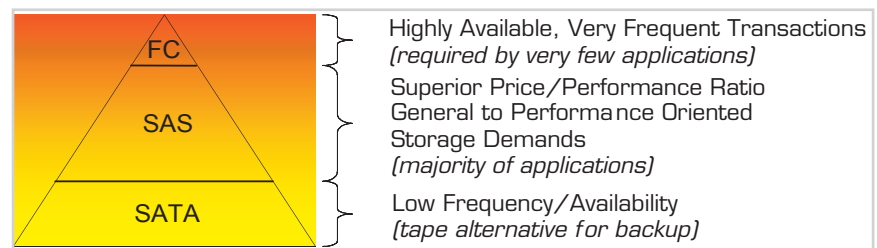

SAS & Fibre Channel - Compared

End-to-End FC Interface Removed

When integrated into a RAID system, the SAS disk drive will seamlessly integrate into FC networked environments. Historically, a homogeneous interface from the host to the device was a requirement for many IT departments. For instance, when the communication initiated with Fibre Channel at the host, the storage device native interface was normally Fibre Channel due to real, as well as unfounded, perceptions of interoperability. As discussed earlier, the SAS drive has overcome interoperability barriers and the prevalence of RAID controllers attached via Fibre Channel will continue. However, within the RAID enclosure, a paradigm shift will soon occur with SAS drives as primary storage and FC-to-SAS conversion occurring on the RAID controller. As mentioned earlier, leveraging SAS expanders within the RAID system is the back-end method for clustering SAS disk drives. RAID systems with SAS drives will be completely transparent to hosts when attached via Fibre Channel.

Utmost Flexibility

Probably the best-known benefit of SAS for external storage is its configuration flexibility. The ability to take a SATA drive and plug it into a SAS midplane without any modifications or changes, and for the controller in the array and software to seamlessly support a system with a mix of SATA and SAS. A portion of SAS drives can be partitioned into one storage pool or LUN and assigned to a server with a transaction-intensive application such as a reservation system, and then another portion of SATA can be partitioned into a storage pool or LUN and assigned to a different server running a reference application such as medical imaging. Alternatively, one array could support all SAS drives and a second array connected

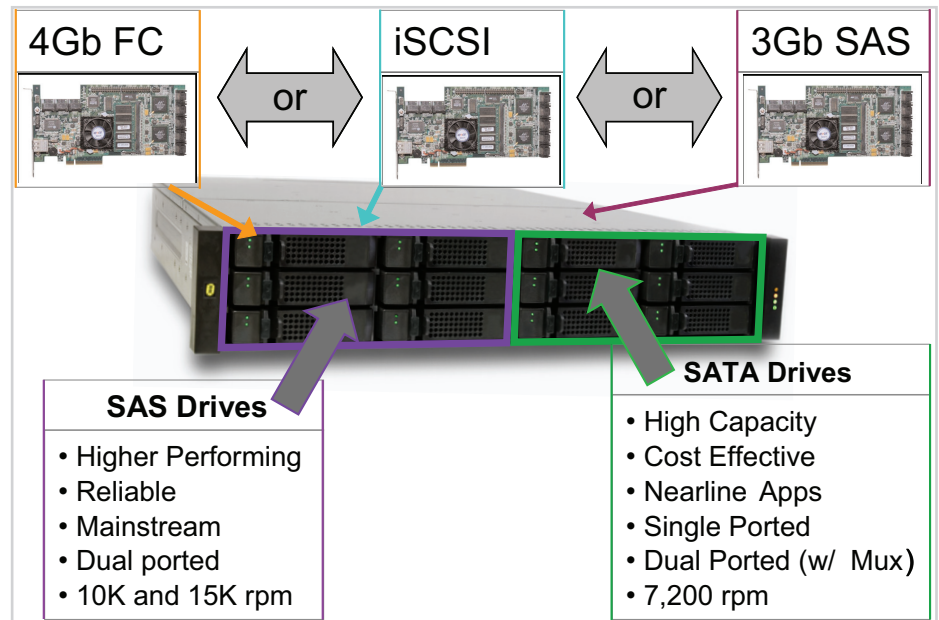

Figure 4 SAS/SATA Flexibility

(or daisy chained) to the first one could support all SATA drives. This flexibility is not possible with Fibre Channel and Parallel SCSI-based subsystems - SAS provides customers with the best of both worlds.

Figure 4. reflects the breadth that the SAS technology offers: the SAS backplane and infrastructure allows for SATA protocols to travel over the same wires. Six drives can be SAS drives and six drives can be SATA within one RAID enclosure. Amplifying this flexibility, the RAID controller could have the option of attaching to one of three networks via a 4Gb FC, iSCSI or 3Gb SAS HIM (Host Interface Module).

Seamless Scalability & Improved Cost of Ownership

Unlike SCSI, which has limitations in its architecture when trying to scale multiple drive enclosures, SAS provides the capability to scale greater than 100 drives or 36 TB with 300GB SAS drives or 56 TB

with 500GB SATA drives, providing very large pools of storage and a cost-effective alternative to Fibre Channel-based SANs. Essentially the components that allow the device to communicate over the FC network are more costly. SAS drives are expected to be priced on par with SCSI drives, and SAS implemented as a host interface and expansion interface on a RAID controller or JBOD I/O module will be less costly than Fibre Channel.

The Nature of SAS and FC Drives

Designed for high performance enterprise requirements and offers both the benefits of backward software compatibility with SCSI and interoperability with Serial ATA (SATA), Serial Attached SCSI (SAS) delivers the flexibility and cost savings previously not possible with traditional storage environments. SAS provides significant benefits to external storage subsystems and offers users "one-stop-shopping" to satisfy their requirements for three main data types: throughput, transaction and reference, highlighted in Table 1.

SAS & Fibre Channel - Compared

SAS Hard Drive with FC Interface Applications

Throughput Data	Transaction Data	Reference Data
<ul style="list-style-type: none"> • High MB/s and large data intensive files • Large block, random read/writes • Low/med res. video streaming • CAD 	<ul style="list-style-type: none"> • Maximum IOPS for OLTP, calculation intensive files • Small block, random read/writes • Reservation systems • Billing systems 	<ul style="list-style-type: none"> • Fixed content, archival data for secondary/ nearline storage • Large block, sequential writes/reads • Imaging • Medical records

analysis, Fibre Channel will have a positive impact - airline computer ticketing systems ten minutes before takeoff. Hence, the number of unique applications Fibre Channel drives will diminish as prudent IT managers replace SAS based storage for most performance-oriented environments.

SAS Roadmap

The SAS roadmap outlines robust growth and investment protection attributes by starting at 3 Gbps, doubling to 6Gbps in 2007 and then doubling again to 12Gbps.

FC Hard Drive with FC Interface Applications

Throughput Data	Transaction Data	Reference Data
<ul style="list-style-type: none"> • Extremely high MB/s and large data intensive files • High volume - large block, random read/writes • High res. video streaming • Collaborative CAD sessions 	<ul style="list-style-type: none"> • Maximum IOPS for OLTP, calculation intensive files • High volume - small block, random read/writes • High volume reservation systems • Billing systems 	<ul style="list-style-type: none"> • Fixed content, archival data for secondary/ nearline storage • Large block, sequential writes/reads • High res. imaging • Medical records

Table 1. FC-SAS and FC-FC Applications

An external subsystem with a SAS mid-plane will support both high-performance, reliable SAS drives, which are ideal for transaction data; and cost-effective, high-capacity SATA drives, which are ideal for reference and throughput data. This provides customers with one platform – instead of two – to support both drive types, thus satisfying all three application segments illustrated above. SAS-based external storage arrays provide benefits in these five areas: performance, availability, flexibility, scalability and total cost of ownership, or TCO.

Will SAS Upstage Fibre Channel?

SAS will be the catalyst to the scrutiny that will occur in IT environments debating the value of access to data. Given the superior price-to-performance ratio, overtaking the performance oriented storage position Fibre Channel has dominated will

be certain for SAS. Indeed, there will continue to be a minority of applications such as online transaction processing and data

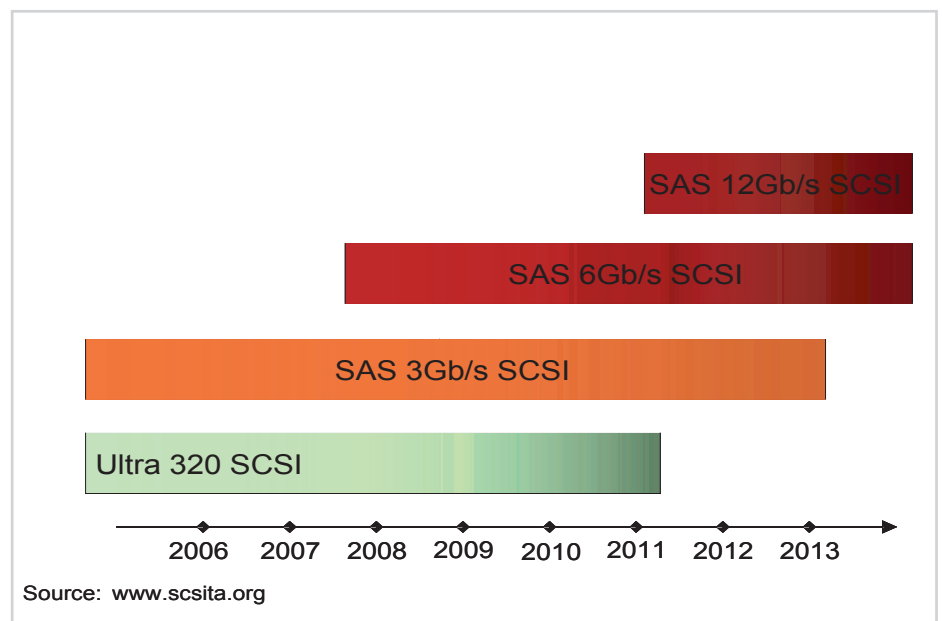

Figure 5 SAS Roadmap

SAS & Fibre Channel - Compared

Conclusion

Serial Attached SCSI, SAS, will offer new levels of performance, availability and customer choice by supporting both enterprise-class Serial Attached SCSI drives and Serial ATA drives for cost-sensitive applications. OEMs and IT managers will have the flexibility to configure storage subsystems with either drive technology, or both, enabling high-performance and low-cost storage in the same subsystem, thus maximizing customers' total return on investment and providing flexibility for future growth. Furthermore:

- SAS will replace parallel.
- SAS will replace direct-attached FC
- SAS will replace FC in external RAID systems (except for high-end SANs)
- Many applications will support SAS and SATA drives within the same system

As the sophistication of evaluating the value of data improves, IT managers will continue to scrutinize the requirement for data to be always available at extremely high data rates. While the FC network continues to be a mainstay, expensive ultra high performance Fibre Channel disk drives will apply to only niche applications. Parallel SCSI disk drives will quickly become extinct in place of very cost-effective disk storage. For the very low cost, high capacity disk drive choice, SATA disk drives will occupy that market space. A great balance between capacity and performance SAS is the natural successor to parallel SCSI, just as SATA is to parallel ATA.

Further, SAS will all but replace Fibre Channel disk drives as IT managers realize the superior price to performance SAS disk drives offer. While offering alternatives to more costly high-end systems, SAS will provide a new tier of storage in the midrange.

SAS will be the foundation of high-end enterprise storage over the next several years. It's the key ingredient to enabling new approaches to tiered storage.

Corporate Headquarters:
2200 Faraday Avenue
Suite 100
Carlsbad, CA 92008, USA
800-872-2783
760-931-5500
Fax: 760-931-5527

Europe:
Marssteden 94
7547 TD Enschede
THE NETHERLANDS
31-53-428-4980